

• *Beginner and Novice*

A 40-Meter DDRR Antenna

BY W. E. ENGLISH,* W6WYQ

SHORTLY AFTER my article on a practical DDRR Antenna appeared,¹ I received a number of inquiries regarding low-frequency versions of this antenna for operation at ground level. After a little experimenting I came up with this version of a 40-meter DDRR which works quite well. In early tests very fine QSOs were held with stations as far away as Phoenix, while the antenna was located inside the garage and surrounded by myriad metallic objects. When the antenna was relocated to the back yard, marked improvement was noted even though this antenna site was marred by a sharp rise of 4 feet in ground elevation, plus close proximity to house wiring and power lines. In spite of these obstacles solid contact was easily achieved with stations up and down the West Coast. Encouraged by these results, we moved the antenna to a roof-top location which put it well in the clear insofar as metallic objects above the ground plane were concerned. In this location the DDRR really proved its worth. In spite of its low profile, a little over one foot, and its very small span, a few inches over nine feet, it was more than adequate when competing with any signal on the band. The obvious conclusion from my experiments is that the 40-Meter DDRR is the apartment dweller's dream. It is principally for that group that this article is prepared. Other interested amateurs might be those who are limited, as I am, by too much house on too little real estate; or those who for other reasons cannot cope with high towers, masts, and guy wires.

Before my enthusiasm sends you out to rip down your inverted V or to dismantle your beam, remember this: the DDRR for all of its capabilities

* 1841 Pinecove Dr., San Luis Obispo, CA 93401.

¹ English, "A Practical DDRR Antenna," 73, June, 1970.

will not supplant a full-size single-frequency antenna which is properly erected over clear terrain. What it will do is provide an antenna which will enable communications of respectable quality, where heretofore it has been impossible because of inadequate space to erect a 40-meter antenna.

Some consideration should also be given to the fact that the high-*Q* nature of the DDRR and its resultant narrow-band characteristics serve to reduce the noise level. Boyer^{2,3} reports that in the initial experiments it was found that DX stations which could copy signals from either a vertical or a DDRR could only be heard on the DDRR due to the reduction in background noise. So if you have a noisy location, it might be to your benefit to try the DDRR, regardless of what antenna you are presently using.

Constructing the 40-Meter DDRR

In this application, 2-inch diameter automobile exhaust pipe was used as the radiating element. The local muffler shop not only supplied the material, but also undertook to bend it to specifications. This was an obvious course since the material and the power bender were right at hand.

The dimensions for 40 meters are:

Ring - 9 foot diameter, center to center.

Height - 12 inches from ground plane to element center.

Gap - 6 inches from upright post center to open end of ring.

In forming the ring to these dimensions, we used four 10-foot lengths of tubing. A 10-degree bend was made at 9-inch intervals in three of the lengths. The fourth length was similarly treated except for the last 18 inches which were bent at right angles to form the upright leg of the ring. One

² Boyer, U.S. Patent Nos. RD 26196, RE 3,151,328 (All rights assigned to the Northrop Corporation).

³ Boyer, "Hula-Hoop Antennas: A Coming Trend?" *Electronics*, January 11, 1963.

About the DDRR

For those who might not be familiar with the DDRR Antenna, a few words of explanation are in order. This antenna, dubbed the Directional Discontinuity Ring Radiator by its inventor, J. M. Boyer, was devised to satisfy a need for very low frequency antennas on ship board. Basically the antenna consists of a 1/4-wavelength element grounded at one end and wound into a single turn coil, a few conductor diameters above the ground (see Fig. 1). Dimensions for resonance are affected by conductor diameter, ring radius, gap separation, and height above ground.

The chicken-wire ground plane is evident in the background. The base plate can be seen at lower right. Note the relative positions of the 52-ohm coaxial feed at the left end of the plate, the flange on the foot of the post, and the tuning unit at the right hand end of the plate.

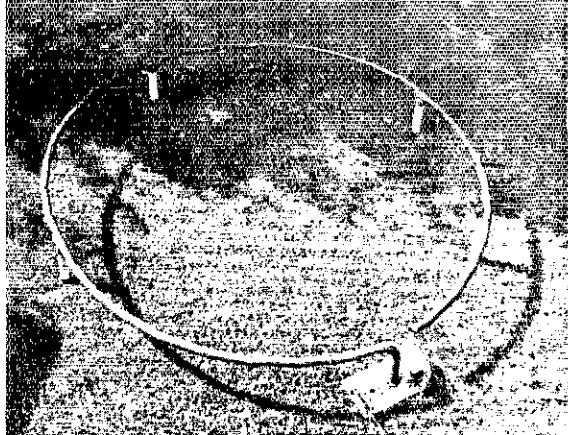

Making the Mounting Plate

The mounting plate is required to provide good mechanical and electrical connections for the grounded leg of the radiator, the coaxial feed-line connection, and the tuning mechanism. If you are using aluminum tubing, you should use an aluminum plate, and for steel tubing, a steel plate to lessen corrosion from the contacting of dissimilar metals. Dimensions for the plate are shown in Fig. 2. The important consideration here is that good, solid mechanical and electrical connections are made between the ground side at the coaxial connector, the ring base, and the tuning capacitor.

The Tuning Unit

We found that the 9-foot ring resonated easily with approximately 20 pF of capacitance between the high end of the ring and the base plate or ground. A 35-pF double-spaced variable from the junk box was pressed into service here (Cardwell

end of each section was flared so that the sections could be coupled together by slipping the end of one into the flare of its mate.

The required flares are easily made at the muffler shop with the aid of the forming tools. Another task which can best be completed at the shop is to weld a flange onto the end of the upright leg. This flange is to facilitate attaching the leg to the mounting plate which provides a chassis for the tuning mechanism and the coaxial-feed coupler. After bending and flaring is complete, the ring is assembled and minor adjustments made to bring it into round and to the proper dimensions. This can best be done by drawing a circle on the floor with chalk and fitting the ring inside the circle. The circle must be slightly larger than the center-to-center diameter so that the reference line can be seen easily. For example, with two-inch tubing the actual diameter of the reference circle must be 9 feet, 2 inches. When you have a satisfactory fit between the tubing ring and the chalk ring, drill a 1/4-inch hole through each of the joints to accept a 1/4-inch bolt. These bolts will clamp the sections together. Also, they can be used to attach the insulators which support the ring at a fixed height above the ground plane.

Making and Attaching the Insulators

Insulators for the antenna were made from 11-inch lengths of 2-inch PVC pipe inserted into a standard cap of the same material. The PVC caps are first drilled through the center to accept the 1/4-inch bolt previously installed at the joints. The caps are then slipped onto the bolts and nuts are installed and tightened to secure the caps in place. The 11-inch length of pipe, when inserted into the cap and pressed firmly until it touches bottom, results in a total insulator length of 12 inches. Four insulators are required: one at each of the joints and one near the open end of the ring for support. It is wise to locate this insulator as far back from the end of the ring as possible because of the increasing high rf voltage that develops as the end of the ring is approached.⁴ As a final measure, the bottom ends of the insulators were sealed to prevent moisture from forming on the inside surfaces. Standard PVC caps could be used here, but we found that plastic caps from 15-ounce aerosol cans fit well.

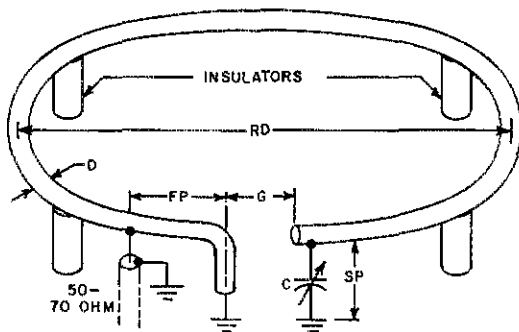

Fig. 1

RD = 0.078λ (28⁴)
 SP = $0.11D$ (2.5⁴)
 FP = $0.25h$ (See Note 1)
 C = (See Note 2)
 D = (See Note 3)
 G = (See Table 1)

Notes: (1) Actual dimension must be found experimentally. (2) Value to resonate the antenna to the operating freq. (3) d ranges upward from 1/2". The larger "d" is the higher efficiency is. Use largest practical size, e.g. 1/2" for 10 meters, 5" or 6" for 80 or 160 meters.

⁴ [EDITOR'S NOTE: Because of the danger of rf burns, in the event of accidental contact with the antenna, precautions should be taken to prevent random access to the completed installation.]

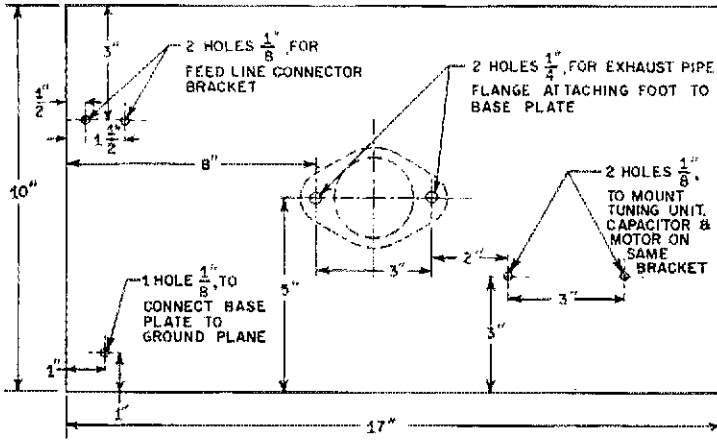

Fig. 2 — Drawing of the base plate which can be made from either steel or aluminum, as described in the text.

NG-35-DS). Any variable which will tune the system to resonance and which will not arc under full power should be satisfactory. Remember, the rf voltage at the high impedance end of this antenna can reach 20 to 30 kV with high power, so if you are using the maximum legal limit, you would do well to consider using a vacuum variable capacitor. Since we limited our power to 500-watts PEP, the double-spaced Cardwell unit was satisfactory. To provide for full band coverage, the capacitor was coupled to a reversible, slow-speed motor which enabled the antenna to be remotely tuned from the operating position. An indicated SWR of 1.1 to 1 was easily achieved over the entire 40-meter band. The motor used was a surplus item made by Globe Industries of Dayton, Ohio.⁵ At 20 volts dc the shaft of this motor turns at about 1 rpm which is ideal for DDDR tuning. The gears used were surplus items. If you cannot obtain gears, string and pulley drive will do almost as well, or you can mount both the motor and the capacitor in line and use direct coupling. Of course, if you operate on a fixed frequency or within a 40- to 50-kHz segment of the band, you can dispense with the motor entirely and simply tune the capacitor manually. In any case, the tuning unit must be protected from the weather. We used a plastic refrigerator box to house the tuning capacitor and its drive motor.

⁵Globe C-5A-1106 (available from Electronic Research Labs Inc., 75 Arch Street, Philadelphia, PA).

Fig. 3 shows the electrical connection for the motor. A small train transformer or power supply for toy slot-cars will work admirably as a tuning motor power source. Standard ac zip cord was used for the connection between the control unit and the motor.

Electrical Connections and the Ground-Plane

The connection between the open end of the ring and the tuning capacitor is made with No. 12 wire or larger. On the end of the base plate opposite the tuning unit, and directly under the ring about 8 inches from the grounded post, install a bracket for a coaxial connector. The connector should be oriented so that the feed line will lead away from the ring at close to 90 degrees. Install a clamp on the ring directly above the coaxial connector. Connect a lead of No. 12 or larger wire from the coaxial connector to the clamp. This wire must have a certain amount of flexibility to accommodate the movement necessary when adjusting the match. The matching point must be found by experimentation. It will be affected by the nature and quality of the ground plane over which the antenna is operating. The antenna will function over earth ground; however, in our location we found the electrical ground to be unpredictable. A ground-plane surface of chicken wire (laid under the antenna and bonded to the base plate) provided a constant ground reference and improved performance. In a roof-top location

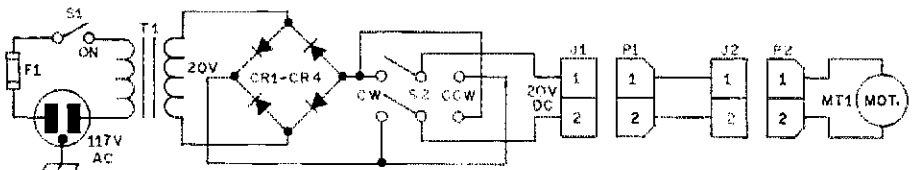

Fig. 3 — Circuit diagram of the power supply and control motor.

- CR1 through CR4 — 1 A, 50 PRV, or equiv.
- F1 — Fuse, 1 A.
- J1, J2 — Two-terminal jack.
- MT1 — Motor (see text).

- P1, P2 — Two-terminal plug.
- S1 — Spst.
- S2 — Dpdt, center off.
- T1 — Transformer (see text).

TABLE I

	Dimensions for 1/4 Wavelength DDRR Elements							
<i>Band (Meters)</i>	160	80	40	20	15	10	6	2
<i>Feed Point (FP)*</i>	12"	6"	6"	2"	1.5"	3"	1"	1/2"
<i>Gap (G)</i>	16"	7"	5"	3"	2.5"	2"	1.5"	1"
<i>Capacitor, pf (C)</i>	150	100	70	35	15	15	10	5
<i>Spacing (Height) (SP)</i>	48"	24"	11"	6"	4 3/4"	3"	1 1/2"	1"
<i>Tubing Diameter (D)</i>	5"	4"	2"	1"	3/4"	3/4"	1/2"	1/4"
<i>Ring Diameter (RD)</i>	36'	18'	9'	4.5'	3'4"	2'4"	16 1/4"	6"

* See Fig. 1 for explanation of designations.

sheet metal roofing should provide an excellent ground-plane. A poor ground usually results in a matching point for the feed line far out along the circumference of the circle. In our installation a near-perfect match was obtained with the feed line connected to the ring about 12 inches from the grounded post. During testing, when the antenna was set up on a concrete surface without the ground plane, a match was found when the feed line was connected nearly 7 feet from the post!

As shown in photos, the compactness of the antenna is readily apparent. The ground plane is made up of three 12-foot lengths of chicken wire, each 4 feet wide, which are bonded along the edges at about 6-inch intervals. In our installation the antenna, with the ground plane, could be dismantled in about 30 minutes. If portability is not important, it is best to bond all of the joints in the tubing so that good electrical continuity is assured.

After all construction is completed, the antenna should be given a coat of primer paint to minimize rust. If it suits you, there is no reason why a final coat of enamel could not be applied.

Tuning Procedures

Once the mechanical construction is completed, the antenna should be erected in its intended operating location. Coupling to the station may be accomplished with either 52-ohm or 72-ohm

coaxial cable. Tune and load the transmitter as with any antenna. While observing an SWR meter in the line, operate the tuning motor. Indication of resonance is the noticeable decrease in indicated reflected power. At this point, note the loading of the transmitter; it will probably increase markedly as antenna resonance is approached. Retune the transmitter and move the feed-point tap on the antenna for a further reduction in indicated reflected power. There is interaction between the movement at the feed tap and the resonance point; therefore, it will be necessary to operate the tuning motor each time the tap is adjusted until the lowest SWR is achieved. Don't settle for anything less than 1.1 to 1. With a good ground and proper tuning and matching, this ratio can be achieved and maintained over the entire band. Once the proper feed point has been located, the only adjustment necessary when changing frequency is retuning the antenna to resonance by means of the motor. If the antenna is to be fixed tuned, provide an insulated shaft extension of 18 inches or so to the tuning-capacitor shaft for manual adjustment. This not only provides insulation from the high rf voltage but also minimizes body-capacitance effects during the tuning process.

Alternatives

A number of materials other than the steel tubing used here are well suited for the ring

The braided lead across the flared joint is to assure electrical continuity. The screws used are self-tapping sheet-metal screws. The top end of the insulator (2-inch diameter PVC pipe) is a standard PVC pipe cap; the bottom is closed off with a cap from an aerosol can (2-inch ID).

Clamps used to connect the feed line and the open end to the capacitor are standard hose clamps. The heavy black lead, center to lower right, is the 52-ohm feed line. The smaller line coming from the plastic housing is the motor control line.

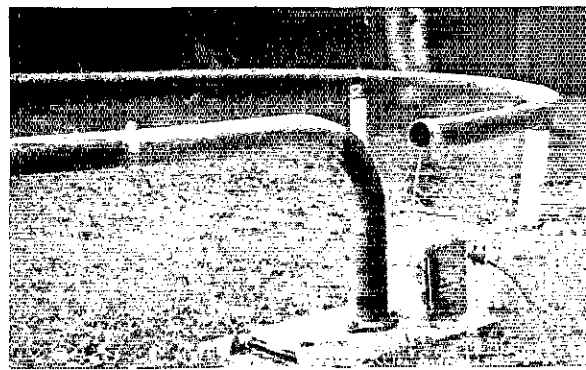
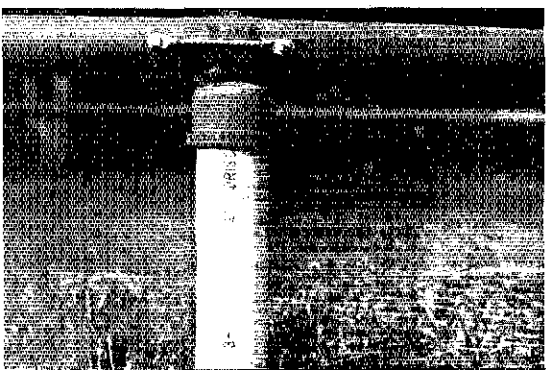

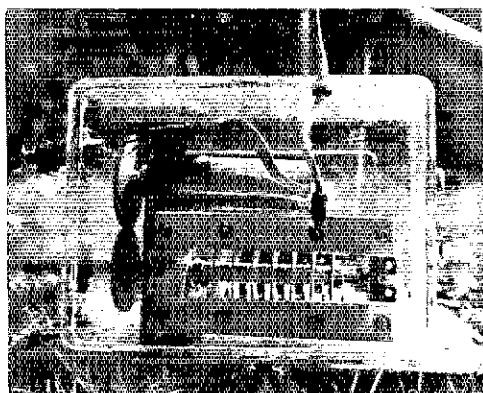

element. Standard E.M.T. or electrical conduit would work as well with a slight increase in weight. One advantage to be gained through the use of conduit is the elimination of the flaring operation since standard couplings would serve to connect each segment of the ring to its adjacent member. Another suitable material is copper tubing. This material is superior to either exhaust pipe or conduit in terms of its conductivity characteristics. Another advantage of copper is that it is available in continuous lengths and the joints could be omitted entirely.

The 2-inch dimension is by no means mandatory. Smaller diameter tubing has been used with satisfactory results.⁶ In fact, DDRR antennas have been fabricated with wire elements. But, if the element diameter is reduced, the antenna tunes more *sharply*. Some experimenters may wish to go in the other direction and use a larger element diameter. I recommend the use of aluminum downspout with a diameter of about 4 inches. This material does not lend itself to bending, however, and the ring must be configured as a regular polygon of eight or more sides. Because of the large number of joints involved, welding is about the only practical means of joining the segments. Unless you are equipped to do this work yourself, the cost of welding might be prohibitive. Anyone who undertakes to make a DDRR antenna of a large element diameter will be rewarded in terms of improved performance.

Performance

Results have been quite encouraging, and it is hoped that more and more hams will equip themselves with the DDRR in the future. The antenna has proved its worth and deserves more investigation by the amateur fraternity than it has been given in the past. No intensive efforts have been made to work DX with the antenna described here; however, a low angle of radiation is conducive to DX, and this antenna demonstrates a low radiation angle. We have found that distant areas, such as the East Coast, are more easily contacted than are stations nearby. All of the results could be attributed to peculiarities of individual stations or skip conditions, but since

⁶ See footnote 1.

The tuning motor, above the capacitor, couples to the capacitor shaft through the gears at left. Both the motor and the capacitor are mounted on a common bracket which attaches to the base plate by two bolts through the weatherproof housing. The lead passing upward through the grommet connects the stator of the capacitor to the open end of the ring.

they are characteristics which can be anticipated with high-efficiency antennas having low radiation angle, we prefer that interpretation. Besides, where else will you find an antenna for 40 meters that is small enough to fit into a corner of the back yard and not protrude above the fence; or for that matter, which could be mounted on the roof of an apartment building or even a ranch-type house and not be visible from the street?

Nearly everyone who listened to the description of this new antenna was enthusiastic. I hope to hear many hams on the air working with the DDRR in the near future.

Parts List

- 4 - 10-ft lengths of 2-inch tubing, exhaust pipe, conduit or copper tubing.
- 1 - base plate 7 1/2 x 19 x 1/8 inches, steel, aluminum, or copper to match tubing.
- 4 - PVC pipe caps for 2-inch pipe.
- 4 feet of 2-inch PVC pipe.
- 2 clamps for 2-inch tubing.
- 4 - 1/4 x 4-inch bolts with nuts.
- 1 reversible motor with 1-rpm shaft output.
- 1 wide spaced variable capacitor, 5 to 35 pF (Millen 16550 or equiv.).
- 1 coaxial connector SO-239.
- 2 sets 2-connector plug and socket for motor control.
- 36 feet of 4-foot chicken wire or equivalent.
- 1 flange to attach tube to base plate.
- 2 - 1/2 x 1-inch bolts with nuts (flange mounting).
- 8 - 3-inch bonding strips No. 8 braided wire.
- 4 plugs 2-inch ID for insulator bases.

Bibliography

- Hicks, "The DDRR Antenna: A New Approach to Compact Antenna Design," *CQ*, June, 1964.
- Horn, "The Half Wavelength DDRR Antenna," *CQ*, September, 1967.
- The Radio Amateur's Handbook*, 46th ed., The American Radio Relay League. 